

- ❑ **3461.660**
1.6 gpf 16-1/2" Height Top Spud Bowl and
Selectronic® Flush Valve

SYSTEM:

- Hydraulically matched to deliver a consistent powerful flush, ensuring a cleaner bowl
- Rapid installation with pre-assembled flush valve, reducing labor time and complexity during installation
- USMCA & TAA Certified
- Single Source Support for all technical and warranty needs
- 5-Year warranty

BOWL:

- High Efficiency. Operates in the range of 1.1 gpf to 1.6 gpf (4.2 Lpf to 6.0 Lpf)
- Permanent EverClean® surface
- 10" or 12" rough-in
- Powerful direct-fed siphon jet action
- Fully glazed 2-1/8" trapway
- 10" x 12" water surface area
- 1-1/2" inlet spud
- Less toilet seat
- Model 3461.001

SELECTRONIC® FLUSH VALVE:

- Factory-Installed CR-P2 Lithium Battery
- Self-Cleaning Piston reduces clogging and maintenance
- State-of-the-Art Electronics prevent ghost flushing
- Dezincification Resistant semi-red brass alloy
- Fully Mechanical Manual Override Button can flush the valve without power
- Sensor range can be adjusted manually or with optional remote control
- Adjustable Tailpiece for rough-in flexibility
- Versatility: Can be installed left or right handed
- Model 6065.161

Includes:

- 047007-0070A Inlet Spud (furnished with bowl)
- 481310-100 2 Bolt caps with retainers (furnished with bowl)
- 1" I.P.S. angle stop with back-flow protection and vandal resistant cap
- 1" Sweat solder kit including cover tube and wall flange
- 1-1/2" High back pressure vacuum breaker, spud coupling and flange



SEE REVERSE FOR ROUGHING-IN DIMENSIONS

System MaP* Score:

- 1,000 grams of miso @ 1.6 gpf
- * Maximum Performance (MaP) testing performed by IAPMO R&T Lab.

Battery Life:

- 5 years @ 4,000 flushes per month

Operating Pressure:

25 psi (flowing) - 80 psi (static)

Flow Requirement:

25gpm (94.6 L/min.)

Nominal Fixture Dimensions:

718 x 356 x 419mm (28-1/4" x 14" x 16-1/2")

To Be Specified:

- ❑ Color: ❑ White
- ❑ Seat:
 - ❑ American Standard #5901.100 Heavy duty open front less cover
 - ❑ American Standard #5905.100 Extra heavy duty open front less cover



5-YEAR LIMITED
WARRANTY on
FIXTURE and
FLUSH VALVE



EVERCLEAN



EPA
WATERSENSE
CERTIFIED

**Fixture Compliance Certifications -
Meets or Exceeds the Following Specifications:**

- ASME A112.19.2 / CSA B45.1 for Vitreous China Fixtures

Valve Listings:

- ASSE 1037/ASME A112.1037/CSA B125.37
- ADA Compliant

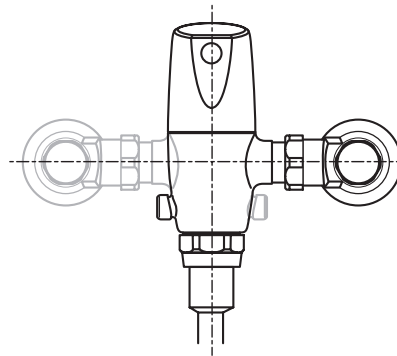
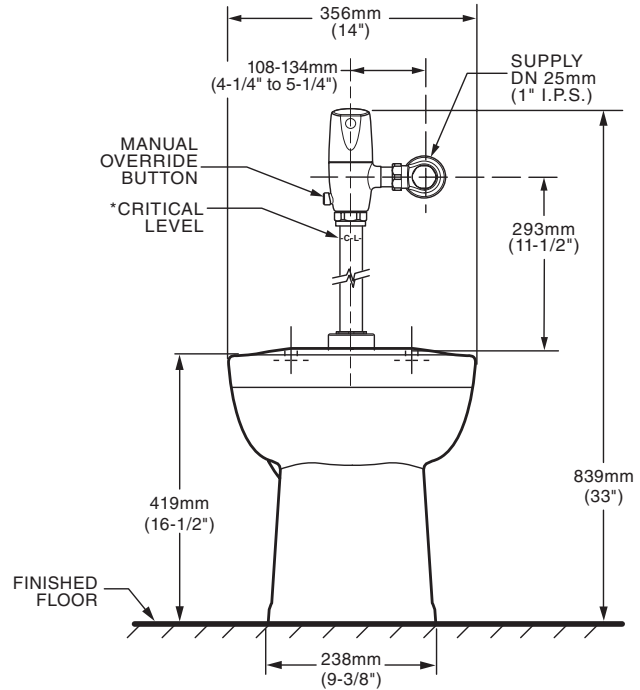
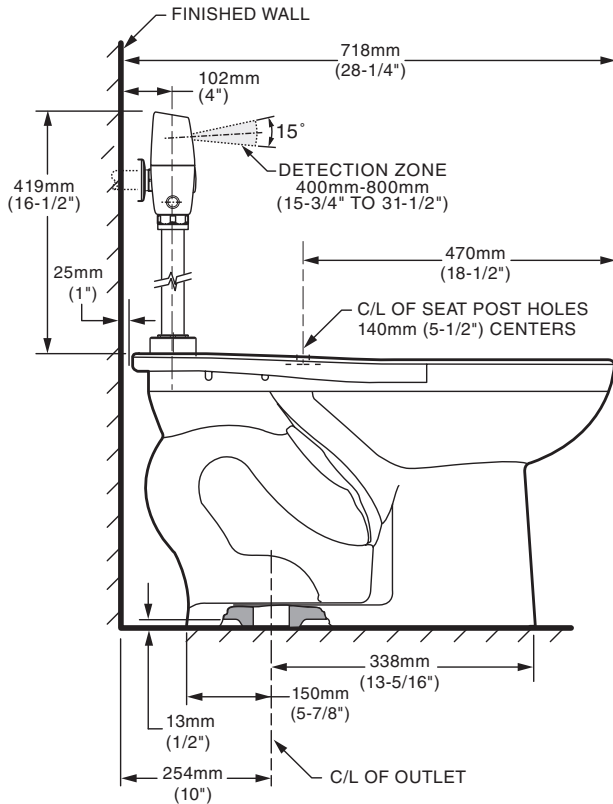

VALVE LEFT or RIGHT HAND INSTALLATION

*Note: The Critical Line (-C-L-) on Vacuum Breaker must typically be a minimum of 6" (152mm) above fixture. Consult Codes for details.



**MEETS THE AMERICANS WITH DISABILITIES ACT GUIDELINES
AND ANSI A117.1 REQUIREMENTS FOR ACCESSIBLE AND USABLE
BUILDING FACILITIES - CHECK LOCAL CODES.**

NOTES:

TO COMPLY WITH AREA CODE GOVERNING THE HEIGHT OF VACUUM BREAKER ON THE FLUSHOMETER VALVE, THE PLUMBER MUST VERIFY DIMENSIONS SHOWN FOR SUPPLY ROUGHING. THIS TOILET DESIGNED TO ROUGH-IN AT A MINIMUM DIMENSION OF 254MM (10") AND A MAXIMUM DIMENSION OF 305MM (12") FROM FINISHED WALL TO C/L OF OUTLET.

IMPORTANT: Dimensions of fixtures are nominal and may vary within the range of tolerances established by ANSI Standard A112.19.2. These measurements are subject to change or cancellation. No responsibility is assumed for use of superseded or voided pages.